

# ISN CLEAN DRAINS SYSTEMS



Complete drain well



Removable internal filter



Internal siphon removal

## Internal siphon



### FEATURES:

- Reduced dimensions and reduced amount of water inside
- Removable, washable and repositionable inside the drain well with clean water or disinfectant
- Position 1: upper perimeter gasket to guarantee the seal with the drain well on the ground
- Position 2: rubber seal with internal siphon closure. Thanks to this seal, the water inside does not remain in contact with any foliar miasms

## Floor drain well



### FEATURES:

- Washable and removable in its entirety
- No interstice on the fund
- With side discharge the lower part is flush with the water drain pipe to ensure complete drainage without stagnation
- Adjustable in height for a perfect levelling with the floor during positioning

# ISN CLEAN DRAINS SYSTEMS

Exploded view drawing



- Selected grating
- Optional filter basket
- Optional water trap
- Drain

Exploded view drawing



- Selected grating
- Adjustable upper part
- Optional filter basket
- Optional water trap
- Lower part

Concrete and tiles with sheet membrane

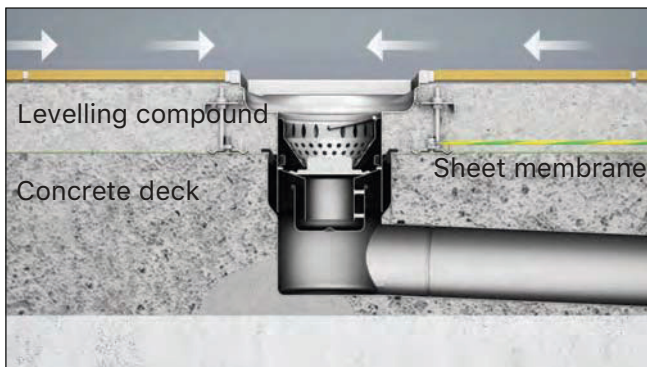

Upper parts & frames

Concrete/tiles



Frame sizes:  
200  
250  
300

Vinyl



Frame sizes:  
200  
300

Epoxy



Frame sizes:  
200  
300



Chute



Pipes and fittings in stainless steel