

ISN *Technology*

Stainless Steel Supply



STAINLESS STEEL CONTAINERS



The Company

Born in 2000, **ISN Technology** is a company that, thanks to the decades-long experience of its founder in the field of production systems for the pharmaceutical industry, produces and sells containers in Stainless steel AISI 304 – AISI 316 for the field of **pharmaceutical, chemicals, homeopathic, cosmetics** and **food products**.

Our products meet the needs of each department of the company, from the laboratory with containers for sampling products, to production with containers and process plants, to the warehouse with palletized or wheeled storage containers.

Our technical office can meet the needs of the customer by designing custom containers, built to answer the manufacturing

specifications set forth in CGMP norms and the materials used conform to FDA directives.

Our containers are available with **P.E.D.** and **ATEX** certification, made for the correct containment and discharge of every type of product: powders, liquids, gels and creams. Possibility of supplying the DQ-IQ-OQ test protocols together with the machine

Our quality standards are our reference point; the quality of materials, eas of cleaning, accurate design and the possibility of customization have always constituted an integral part of **ISN Technology's** quality offer.

**We have the answer
to all your needs!**

In the pages that follow, we present our products.

All exclusively Made in Italy! 



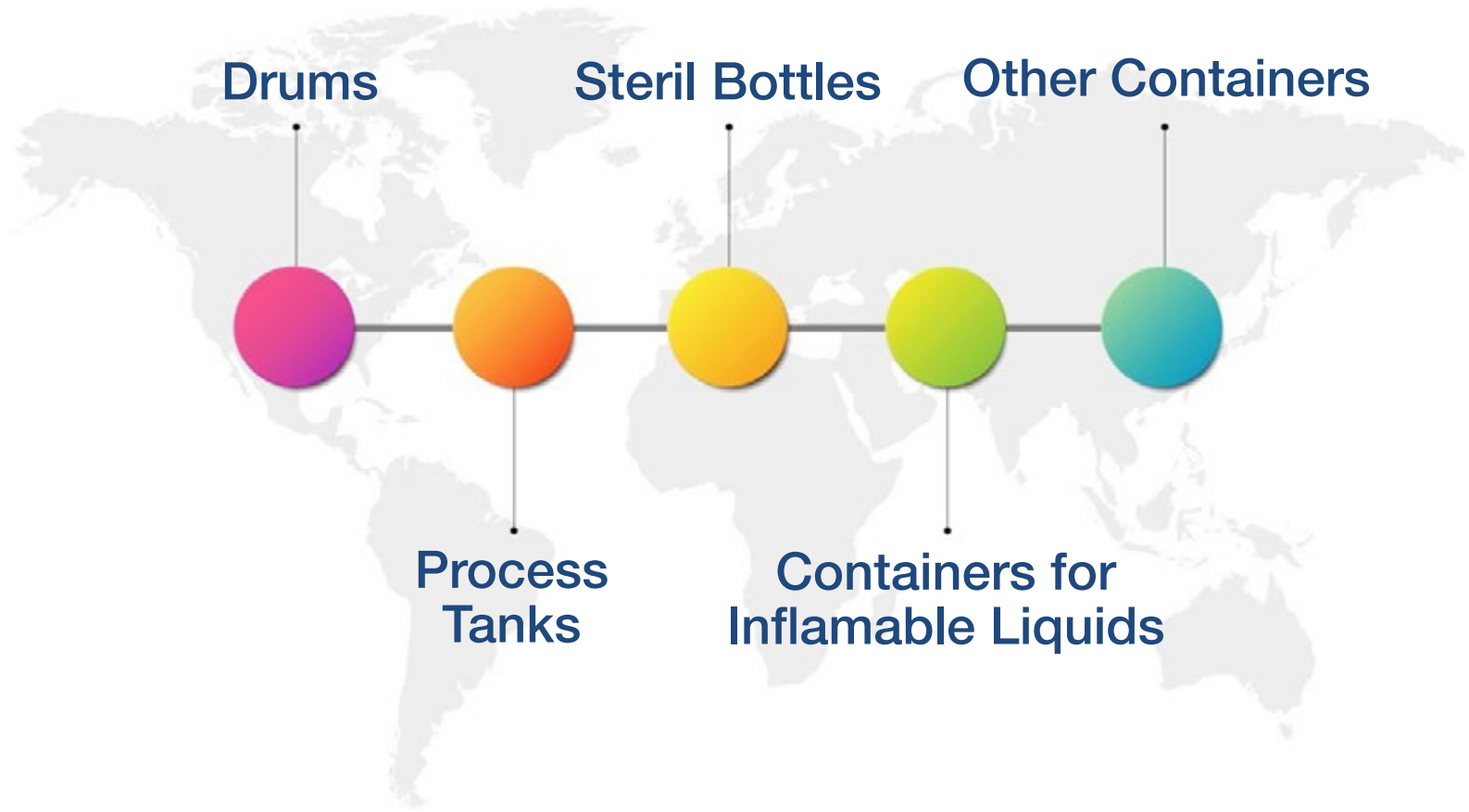

Drums

Made of stainless steel AISI 304 - AISI 316 L according to the C.G.M.P., with flat bottom bottom with rounded corner to allow a correct cleaning, easily removable silicone gasket, top cover with a conical profile or closed top with manual clamp lock completely in stainless steel.

Standard finish, internally glossy mirror, externally satin. Internal and external weldings completely removed and finished. By installing the flat lid, the drums can be stacked.

STANDARD CAPACITY FROM 1 TO 200 LITERS



Process Tanks

We build Thermo-conditioned process tanks, wheeled dissolvers, insulated storage tanks, PED pressure tanks, turbo-emulsion mixers, ATEX-compliant tanks, special tanks for laboratories.



Steril Bottles

Our STERIL containers are designed and manufactured to meet CGMP and FDA standards. The accurate internal and external finishes, the type of construction and the weight make these containers particularly suitable for handling active products. The upper nozzle made with a Tri-Clover 4" (Ø 101.6 mm) or 6" (Ø 152.4 mm) ferrule allows installing high-containment valves.



Containers for inflammable liquids

Certified containers for the storage and transport of flammable liquids.
Made of AISI 316 stainless steel with PTFE gaskets for high chemical resistance.
With pressure control valve (approx. 0.3 bar vent) in the metering device or screw cap.



Other containers

Stainless steel AISI 304 containers. We offer several different types for dosing, transport and storage of products.



Engineering Support

ISN Technology technical office meets the needs of its customers by designing customized containers

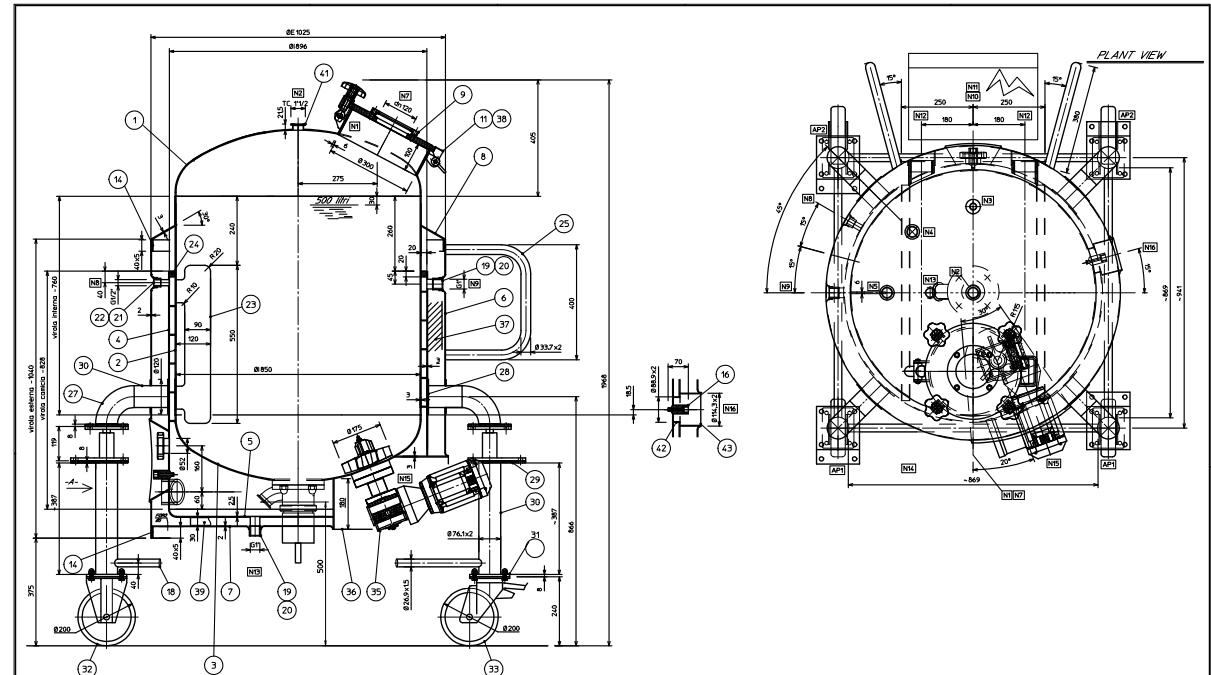
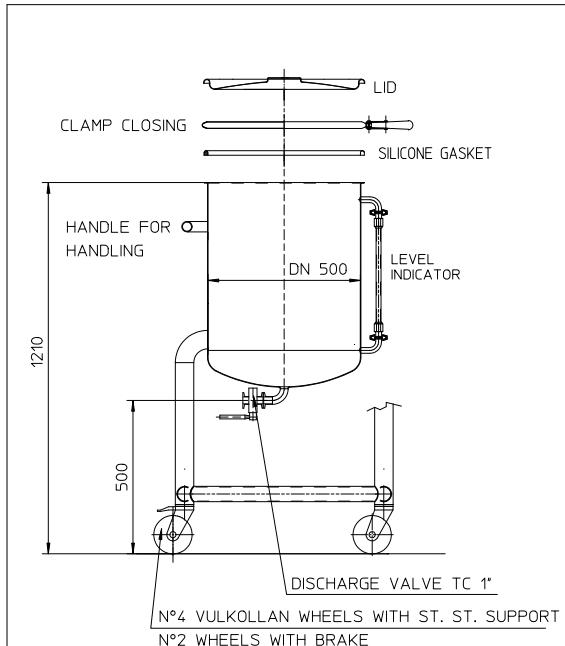

REV.	DATA	DESCRIZIONE	FIRMA
QUOTE SENZA INDICAZIONE DI TOLLERANZA ; GRADO DI PRECISIONE MEDIO UNI-EN 22768-1 -2			
DISEGNATO		SCALA	DATA
ISOLA		1/10	21/01/2018
DISEGNO		APPROVAZIONE	NOTE
3C0221			
REV			0

WHEELED BIN DN500 CAP. 100 LT
WITH LEVEL

QUESTO DISEGNO NON PUO' ESSERE RIPRODOTTO O DATO SENZA NOSTRA AUTORIZZAZIONE SCRITTA
THIS DRAWING CANNOT BE REPRODUCED OR GIVEN UP TO THIRD PARTIES WITHOUT OUR WRITTEN AUTHORIZATION

01						
02						
03						
04						
REVISIONI - DESCRIZIONI						
DATA	REVISIONI	DESCRIZIONE	DATA	FIRMA		
2420-15			Project - Foglio 14			

Our main customers

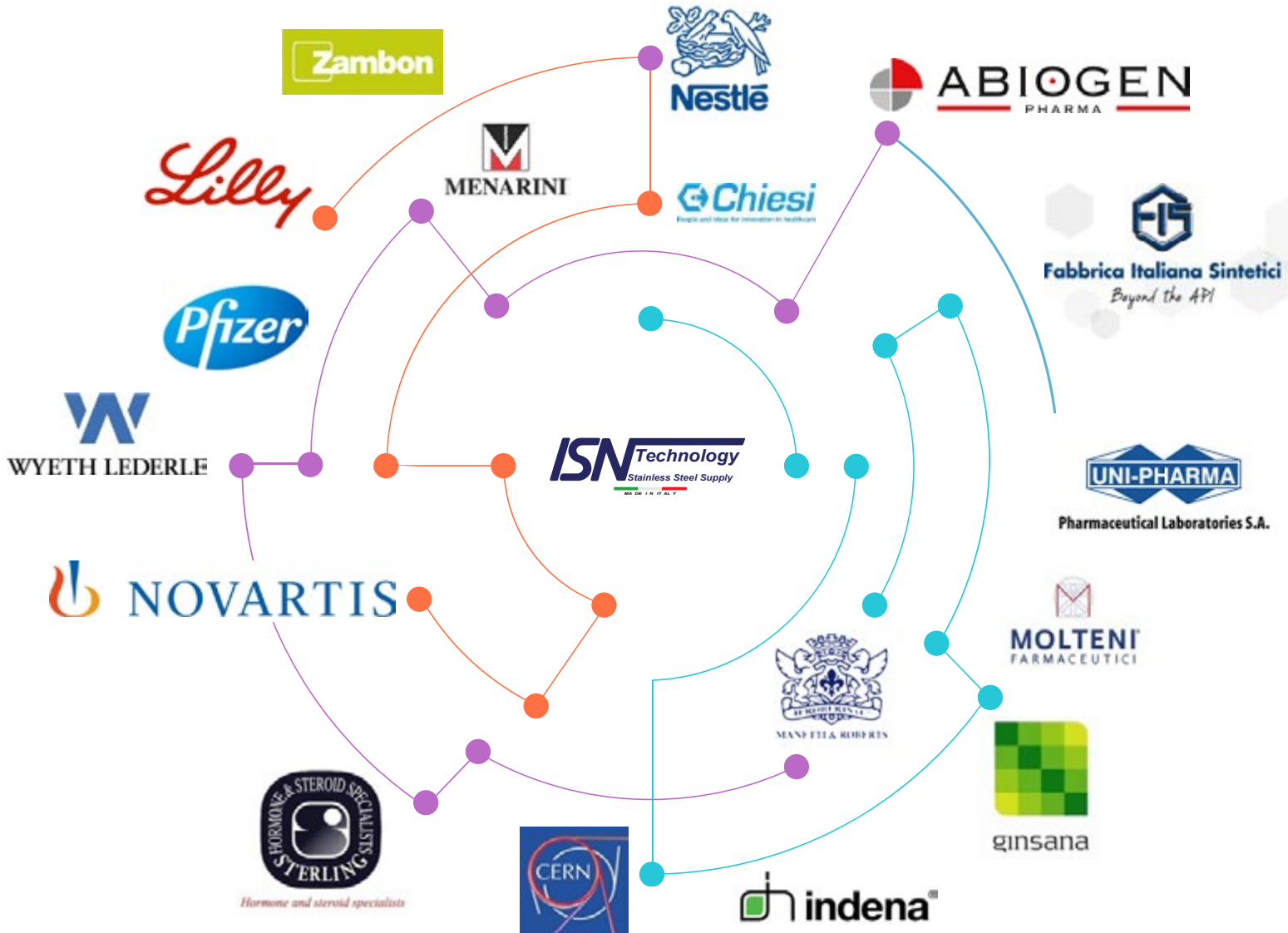

Thanks for your attention



ISN Technology S.a.s.

Via Ludovico Poschi Meuron 70/C

San Marco 55100 LUCCA - ITALY

Tel. +39 (0)583 996445 - Fax. +39 (0)583 393765

www.isntechnology.it - info@isntechnology.it